

<u>Contents</u>	<u>page</u>
Safety Precaution	3
Important safeguards	3
Looking after your Micro/Micro Plus	3
Introduction	3
Before you begin Micro/Micro Plus system Overview	4
Micro Medical Digital Volume Transducer	5
Cleaning the Micro Medical Digital Volume Transducer	6
Micro/Micro Plus exploded view	7
Disassembling the Micro/Micro Plus for Circuit Investigation	8
Reassembling the Micro/Micro Plus	9
Circuit description	10
Technical Data	12
Technical support	13
Parts List	14
Circuit Diagram	15

# Micro/Micro Plus Service Manual

051-07 Iss. 1.0 September 1998

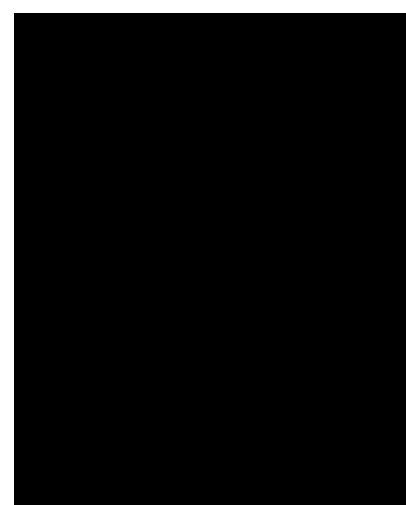

# **Micro/Micro Plus**

## **Service Manual**

---

Information in this document is subject to change without notice and does not represent a commitment on the part of Micro Medical Limited. Only the parts supplied by Micro Medical Limited should be used to complete the service operation described in this manual. If in any way you feel unsure about the successful completion of the service operation you should contact Micro Medical Limited or its appointed agent in your country or region and arrange the despatch of the product to a Micro Medical Limited Service Centre.

Copyright 1998 by Micro Medical Limited All rights reserved

Drawing no. 051-

Version 1.0

September 1998

All other products are trademarks or registered trademarks of their respective owners.

---

## **Safety Precaution**

The servicing of this device is intended to be carried out by a properly trained and competent electronics engineer, or experienced in the maintenance and servicing of medical devices. Read this manual thoroughly before proceeding with the service. If in any doubt please contact the service centre at Micro Medical Limited or their accredited agent in your country or region.

---

## **Important Safeguards**

- o Read all of the instructions.
- o Keep the instructions in a safe place for later use.
- o Follow all warnings and instructions marked on the product.
- o When replacement parts are required, be sure to use replacement parts specified by Micro Medical that have the same characteristics as the original parts. Unauthorised substitutions may result in fire, electric or other hazards.
- o Do not place on an unstable table.
- o The product should be operated only from the type of power source indicated on the label.

---

## **Looking after your Micro/Micro Plus Spirometer**

- o Avoid exposing the Micro/Micro Plus Spirometer to direct sunlight.
- o Avoid operating the spirometer in dusty conditions or near to heating appliances or radiators.
- o Do not keep the spirometer in a damp place or expose it to extreme temperatures.
- o Do not direct the transducer holder towards a strong light source whilst operating the spirometer.

---

## **Introduction**

This service manual provides you with information to carry out the servicing operation of the Micro/Micro Plus Spirometer. should the unit become faulty It is a process, which is relatively straightforward but must be carried out in a logical sequence. Our advice is to familiarise yourself with the contents of this manual before attempting to carry out the procedure of replacing the parts supplied in the service kit for the Micro/Micro Plus Spirometer.

---

## **Before You Begin**

Before you begin the servicing operation, please read the section on Circuit description very carefully:

## Micro/Micro Plus system overview.

The Micro Medical Micro/Micro Plus Spirometer consists of a hand held microcomputer unit (2) incorporating a Micro Medical digital volume transducer (1).

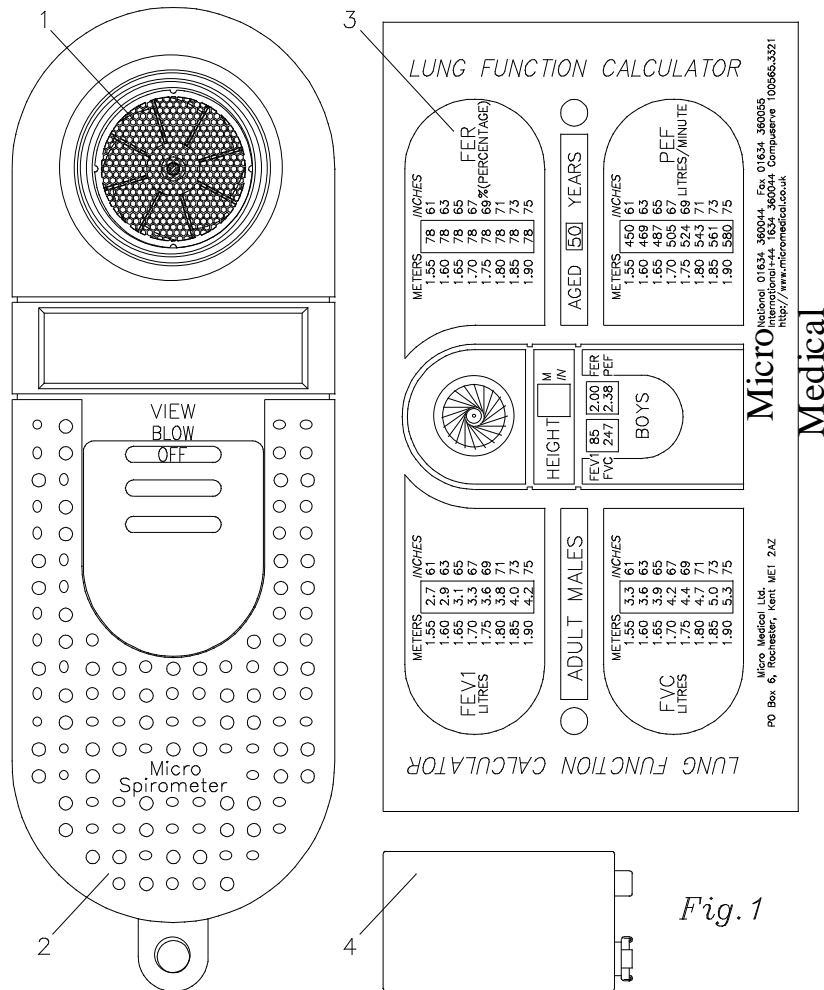
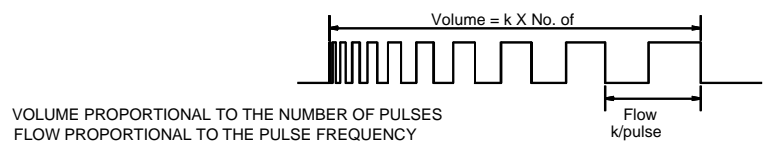
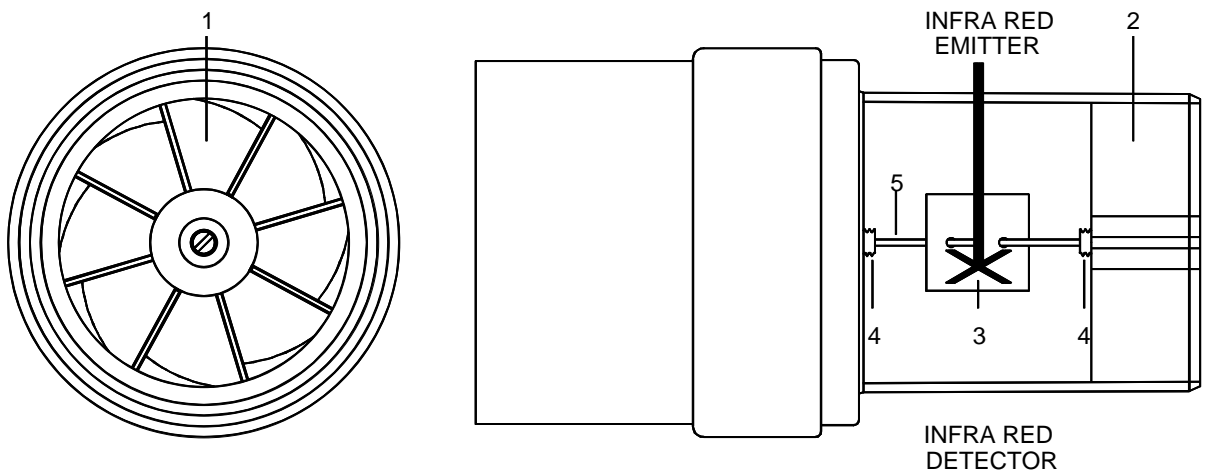

Fig. 1

1. Micro Medical Digital Volume Transducer.
2. Micro microcomputer unit.
3. Lung Function Calculator.
4. PP3 Alkaline battery (BAT2).

## Micro Medical Digital Volume Transducer

The Micro Medical digital volume transducer consists of an acrylic tube with a vane (3) positioned between a stator (1) and a cross bar (2). The low inertia vane is attached to a stainless steel pivot (5) which is free to rotate on two jewelled bearings (4) mounted at the centre of the stator plate and cross bar. As air is passed through the transducer a vortex is created by the stator, which causes the vane to rotate. The number of rotations is proportional to the volume of air passed through the transducer and the frequency of rotation is proportional to the flow rate. The transducer passes through the PCB, which contains a light emitting diode (LED) and phototransistor. The LED produces an infrared beam, which is interrupted by the vane twice per revolution. This interruption is sensed by the phototransistor giving a square wave output on the collector. There is no routine maintenance required for the transducer other than cleaning.



---

## **Cleaning the Digital Volume Transducer**

The transducer requires no routine maintenance or servicing. However if you wish to sterilise or clean the transducer it may be removed by the following procedure.

1. Remove the transducer by gently pulling from the main body with a twisting action.
2. The transducer may now be immersed in warm soapy water for routine cleaning or immersed in a cold sterilising solution e.g. Alkacide for a period not exceeding 15 minutes. **(Alcohol and chloride solutions should be avoided.)**
3. After cleaning or sterilising, the transducer should be rinsed in distilled water and dried.
4. Reassemble the transducer into the Micro/Micro Plus Spirometer.

**Alkacide is available from Micro Medical in convenient 250ml plastic bottles (Cat No. SSC1000)**

---

## Micro/Micro Plus Spirometer exploded view (fig 1)

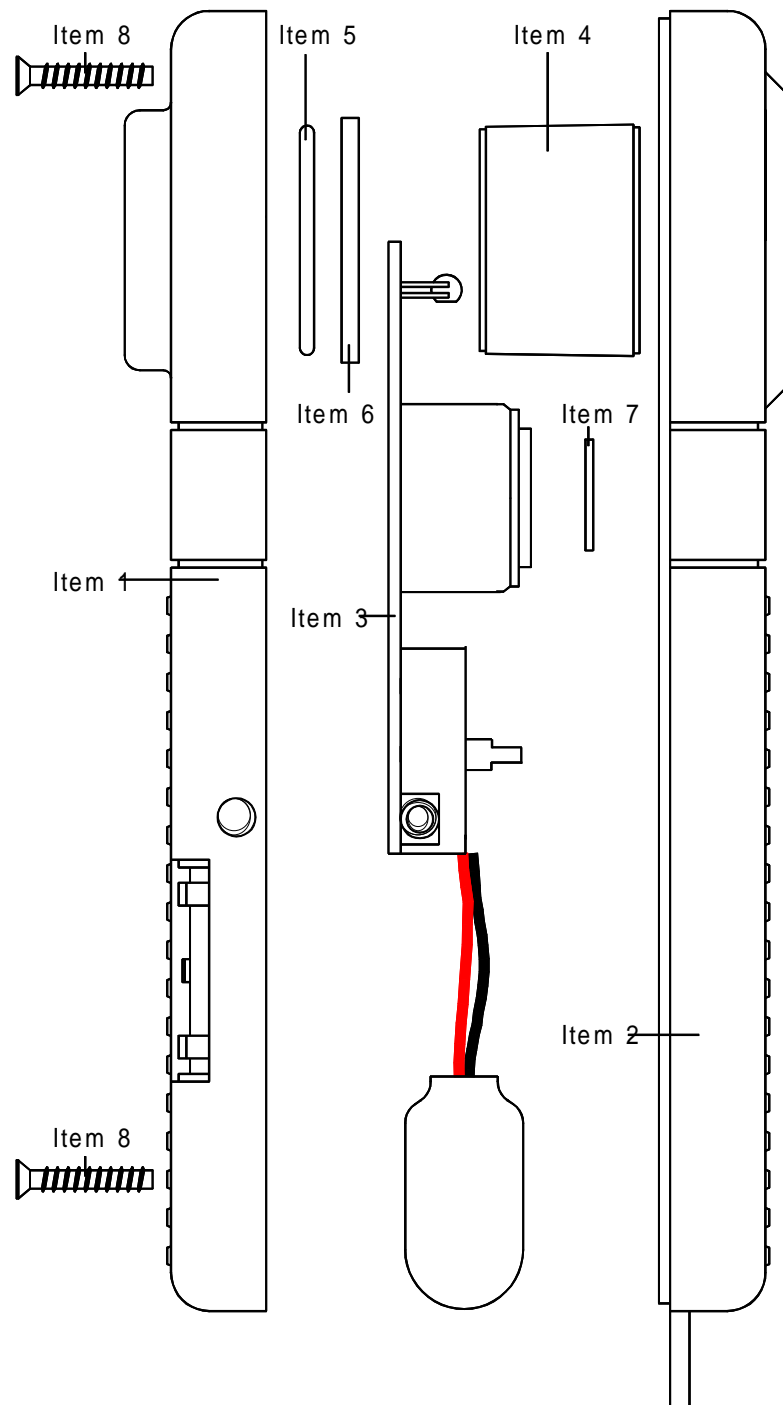

- |                         |                        |
|-------------------------|------------------------|
| 1. Bottom Moulding      | 2. Top Moulding        |
| 3. PCB Assembly         | 4. Turbine sleeve      |
| 5. Coated O ring        | 6. O ring capture ring |
| 7. Polycarbonate window | 8. 2 x Screws          |

---

## **Disassembling the Micro/Micro Plus for Circuit Investigation.**

If the Micro/Micro Plus Spirometer becomes faulty then the following procedure is needed to investigate the fault.

- 1 Remove the digital volume transducer from the microcomputer unit by gently pulling the transducer from the microcomputer unit with a twisting action.
- 2 Turn the unit face down and slide back the battery cover.
- 3 Remove the battery and place to one side.
- 4 Remove the 2 screws on the bottom moulding.
- 5 Turn the Micro/Micro Plus face up and ease the top moulding from the bottom and turn the top moulding over so as the unit is in two halves.
- 6 Remove the PCB from the bottom moulding and put the bottom moulding to one side.
- 7 The Micro/Micro Plus is now ready for fault finding



---

## Reassembling the Micro/Micro Plus

1. Place the PCB into the bottom moulding and wire battery lead as shown in fig 2.
2. Replace items 4, 5 and 6 (Fig1) into the bottom moulding.
3. Position top moulding on top of bottom moulding and push together (**ensure that the battery leads are not trapped**).
4. Turn unit face down and replace the 2 screws.
5. Replace the PP3 battery ensuring correct polarity.
6. Replace the battery cover.
7. Turn the unit face up and refit transducer into the microcomputer unit.
8. The unit is now ready for operation.

**Fig 2**

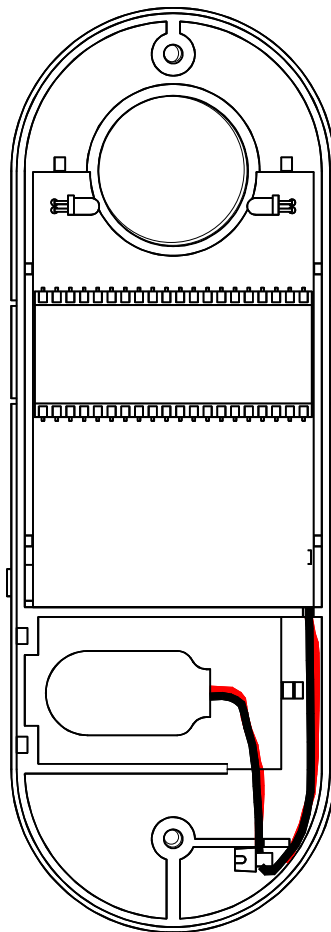

---

## Circuit description

The circuit is based on the Motorola one time programmable (OTP) microcontroller MC68HC705C9ACFN (IC1) operating at a clock frequency of 1 MHz. This processor contains 7 Kbytes of EPROM, 176 Bytes of RAM, programmable output latches, and a serial peripheral interface (SPI). The processor monitors pulses from the transducer, calculates the spirometry measurements, and directly drives the LCD display according to the position of the slide switch. The state of the battery is also monitored and a warning is displayed when necessary. Calibration information is stored in a 256 bit serial EEPROM, IC5, and communicates with the microcontroller via the SPI.

### Reset

The reset circuit consists of a single chip reset (IC7) which holds the reset line low for 350ms after the 5 volt supply has reached the threshold voltage of 4.5 volts. The reset signal is then applied to the microprocessor (IC1),

### Power Supply

The unit is powered an alkaline 9 volt PP3 battery (BAT1) and switched by IC3 which is arranged in a bi-stable configuration. When the unit is turned on via the slide switch a momentary pulse appears on pin 1 of IC3 by the action of R8, R9 and C10. This pulse toggles the bi-stable circuit so that pin 11 of IC3 will go low turning transistor TR4 on and supplying 9 volts to the low drop out regulator (IC4). When the unit is turned off pin 13 of IC3 is pulled low reversing the bi-stable action and turning TR4 off. If the unit is left on without use for 6 minutes then pin 31 of IC1 is driven high under software control turning on TR5 which will turn the unit off via the bi-stable circuit.

### Battery monitoring

The terminal voltage of the battery is monitored by the action of R4, R5, R6, and TR2. The emitter of TR2 is held at 5 volts and the base voltage is derived from the battery through the potential divider formed by R4 and R5. When the battery voltage falls to approximately 6 volts, the voltage on the base of TR2 is 4.4 volts and the transistor turns on. The collector will rise to about 4.6 volts and this is monitored by the processor on pin 13 (PB0) when the unit is switched on. When a low battery condition is detected the processor signals to the user that the battery is low by flashing the letters **bat** three times on the display accompanied by an audible warning.

## **Display**

The display is a custom 3½ digit low power LCD. The seven segments of three digits are driven directly by ports A, B and C of the microcontroller with port PA0 driving the back plane. The decimal point, “1” digit, and the other legends are driven by the 8 bit shift register, IC2, which is controlled by the microcontroller via the SPI interface. The back plane is driven by a square wave of nominally 60 Hz. The individual segments are driven by a similar square wave, which is in phase with the backplane when the segment is off and 180 degrees out of phase when the segment is on.

## **Serial Interface (Micro Plus unit only)**

Serial communications are established from the microprocessor to the external RS232 port using its serial communications interface (IC6)

## **Transducer interface**

The rotation of the vane inside the transducer is sensed by the interruption of an infrared beam produced by the LED and sensed by the phototransistor. The LED is controlled by the emitter follower (TR1) and is only energised during a spirometry test when the BLOW legend on the display is showing.

The light beam is detected by the phototransistor, which is in common emitter configuration. The load resistor is factory adjusted using VR1 to give the largest collector swing when the turbine is subjected to a flow of air at 37 degrees Celsius saturated with water vapour. VR1 is factory set and should not be adjusted by the user. The signal at the collector is conditioned by the action of the schmitt inverter (IC3) and applied to the pulse capture input of the microcontroller (Pin 42 of IC1). The microcontroller calculates the expired volume and flow from the number and rate of received pulses.

## **Calibration**

The sensitivity of the Micro Medical digital volume transducer depends only upon the fixed geometry of the stator and is inherently stable. The calibration will be unaffected by any dirt which may build up on the stator due to poor cleaning procedures. However, physical damage to stator may adversely affect calibration and in this instance the unit should be returned to Micro Medical for transducer replacement and re-calibration. At Micro Medical calibration is performed with a computer controlled waveform generator, approved by the American Thoracic Society.

---

## **Technical Data**

### **Transducer Type**

Micro Medical Uni-Directional Digital Volume

### **Resolution**

10ml

### **Accuracy**

+/-3%. (To ATS recommendations Standardisation of Spirometry 1994 update for flows and volumes).

### **Volume Range**

0.1-9.99 litres B.T.P.S

### **Flow Range**

30L/min-1000L/min

### **Display**

Custom 3½ digit Liquid crystal

### **Power Supply**

9V PP3 dry cell

### **Dimensions**

170 x 60 x 70mm (including transducer)

### **Weight**

Unit only: 150g

Unit and accessories: 550g

### **Operating temperature**

0 to +40°C

### **Operating Humidity**

30% to 90% RH

### **Storage Temperature**

-20 to +70°C

### **Storage Humidity**

10% to 90% RH

---

## Technical Support

### Great Britain and World Headquarters

Micro Medical Ltd

PO Box 6

Rochester

Kent ME1 2AZ

Telephone + 44 (0)1634 360044

Fax +44 (0)1634 360055

Web Site <http://www.micromedical.com.uk>

Email [support@micromedical.com.uk](mailto:support@micromedical.com.uk)

**Contact Micro Medical Ltd for the local agent in your region or country for local service:**

## Parts List

Designation	Description
IC1	<b>(MC68HC705C9ACFN)</b> MOTOROLA SURFACE MOUNT OTP MICROCONTROLLER
IC2	<b>(74HC164)</b> 8 BIT SURFACE MOUNT SERIAL TO PARALLEL SHIFT REGISTER
IC3	<b>(4093)</b> SURFACE MOUNT QUAD SCHMITT NAND GATE
IC4	<b>(LM2931M-5.0)</b> LOW DROP OUT LOW POWER SURFACE MOUNT 5 VOLT REGULATOR
IC5	<b>(93C06)</b> 256 BIT SERIAL SURFACE MOUNT EEPROM
IC6	<b>(MAX3221CAE)</b> SURFACE MOUNT RS232 TRANSCEIVER <b>(MICRO PLUS ONLY)</b>
IC7	<b>(DS1233D-10)</b> DALLAS ECONO RESET
TR1	<b>(DTB113EK)</b> RHOM PNP DIGITAL TRANSISTOR
TR2	<b>(FMMT591)</b> ZETEX PNP TRANSISTOR
TR3	<b>(SDP8405)</b> HONEYWELL PHOTOTRANSISTOR
TR4	<b>(FMMT591)</b> ZETEX PNP TRANSISTOR
TR5	<b>(DTC114EK)</b> RHOM NPN DIGITAL TRANSISTOR
LED	<b>(SEP8705)</b> HONEYWELL INFRA RED LED
D1	<b>(BAT42)</b> GENERAL PURPOSE SCHOTTKY DIODE
DISPLAY	3½ DIGIT CUSTOM DISPLAY
R1	2.2M SURFACE MOUNT RESISTOR 0.1 WATT 5% SIZE 0805
R2	120 OHM ¼ WATT 5% RESISTOR
R3	1K SURFACE MOUNT RESISTOR 0.1 WATT 5% SIZE 0805
R4	33K SURFACE MOUNT RESISTOR 0.1 WATT 5% SIZE 0805
R5	100K SURFACE MOUNT RESISTOR 0.1 WATT 5% SIZE 0805
R6	100K SURFACE MOUNT RESISTOR 0.1 WATT 5% SIZE 0805
R7	100K SURFACE MOUNT RESISTOR 0.1 WATT 5% SIZE 0805
R8	1M SURFACE MOUNT RESISTOR 0.1 WATT 5% SIZE 0805
R9	1M SURFACE MOUNT RESISTOR 0.1 WATT 5% SIZE 0805
R10	100K SURFACE MOUNT RESISTOR 0.1 WATT 5% SIZE 0805
R11	10K SURFACE MOUNT RESISTOR 0.1 WATT 5% SIZE 0805
R12	100K SURFACE MOUNT RESISTOR 0.1 WATT 5% SIZE 0805
R13	10K SURFACE MOUNT RESISTOR 0.1 WATT 5% SIZE 0805
VR1	20K SINGLE TURN POTENTIOMETER
C1	<b>(16MH547M6357)</b> RUBYCON 47µF 16 VOLT ELECTROLYTIC CAPACITOR
C2	<b>(16MH547M6357)</b> RUBYCON 47µF 16 VOLT ELECTROLYTIC CAPACITOR
C3	47pF CERAMIC CAPACITOR SIZE 1206
C4	47pF CERAMIC CAPACITOR SIZE 1206
C5	0.33µF SURFACE MOUNT MULTILAYER CERAMIC SIZE 0805 <b>(MICRO PLUS ONLY)</b>
C6	47nF SURFACE MOUNT MULTILAYER CERAMIC SIZE 0805 <b>(MICRO PLUS ONLY)</b>
C7	0.33µF SURFACE MOUNT MULTILAYER CERAMIC SIZE 0805 <b>(MICRO PLUS ONLY)</b>
C8	0.33µF SURFACE MOUNT MULTILAYER CERAMIC SIZE 0805 <b>(MICRO PLUS ONLY)</b>
C9	0.1µF SURFACE MOUNT MULTILAYER CERAMIC SIZE 0805
C10	0.1µF SURFACE MOUNT MULTILAYER CERAMIC SIZE 0805
SK1	<b>(JY-3530)</b> 3.5mm STEREO JACK SOCKET <b>(MICRO PLUS ONLY)</b>
PL1	4 WAY 0.1" PITCH PIN HEADER <b>(MICRO ONLY)</b>
SW1	<b>(SLF2300)</b> DOUBLE POLE 3 POSITION SLIDE SWITCH
SPKR	<b>(PKM35-4A0)</b> MURATA PIEZO CERAMIC SOUNDER
BAT1	DURACELL PROCELL PP3 9V BATTERY
X1	4MHz CERAMIC RESONATOR
TP1	1mm PRESS FIT TERMINAL POST
TP2	1mm PRESS FIT TERMINAL POST



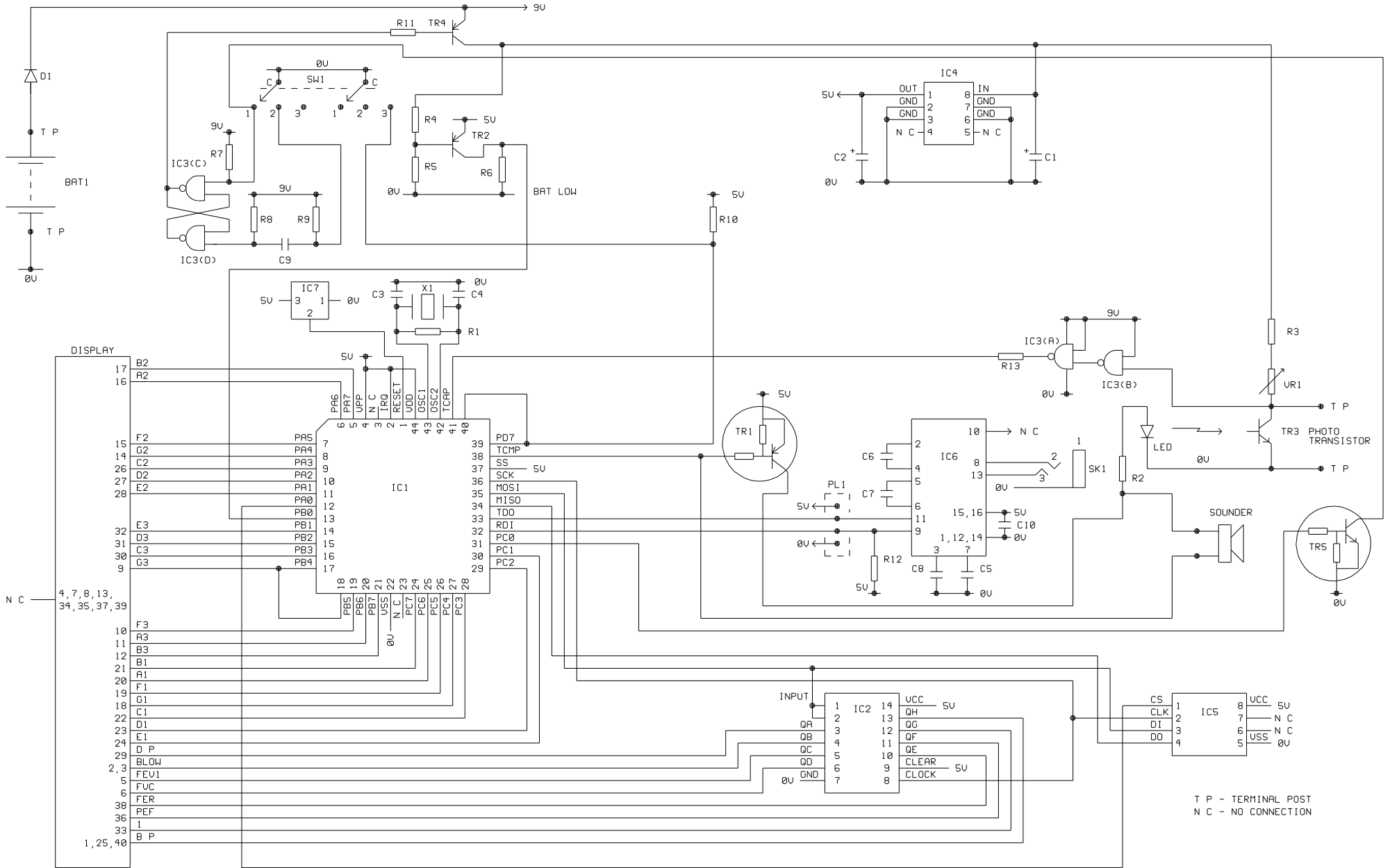

DRAWN C P L	TITLE MICRO/MICRO PLUS	ISSUE	DATE	DESCRIPTION OF MOD	DATE	DESCRIPTION OF MOD
DATE 23/6/98	DRAWING No 051-01	1 2				